

Item	QTY	Part Number	Description
1	1	5300	Chassis
2	1	5306	Weight
3	1	5305	Dust Skirt Clip
4	1	C319	Handle
5	1	5304	Dust Skirt
6	2	9104	Handlebar grip
7	2	C321	Threaded Knob

TITLE: Chassis Assembly



SPE International Ltd
 Honeyholes Lane, Dunholme
 Lincoln UK LN2 3SU
 Tel: +44 (0)1673 860709
 Fax: +44 (0)1673 860330
 Web: www.spe-int.com
 Email: info@spe-int.com

Machine: DFG200-3

Revision: 1.01

Drawn: PM

Checked: BJ

Date: 06/12/2009

THIS DRAWING AND ASSOCIATED COPYRIGHT IS
 THE PROPERTY OF SPE INTERNATIONAL LTD

Item	QTY	Part Number	Description
1	1	7017A	Electric motor 230v
2	1	5303	Drive coupling
3	1	5226	Flexi coupling
4	1	5064A	Adaptor plate

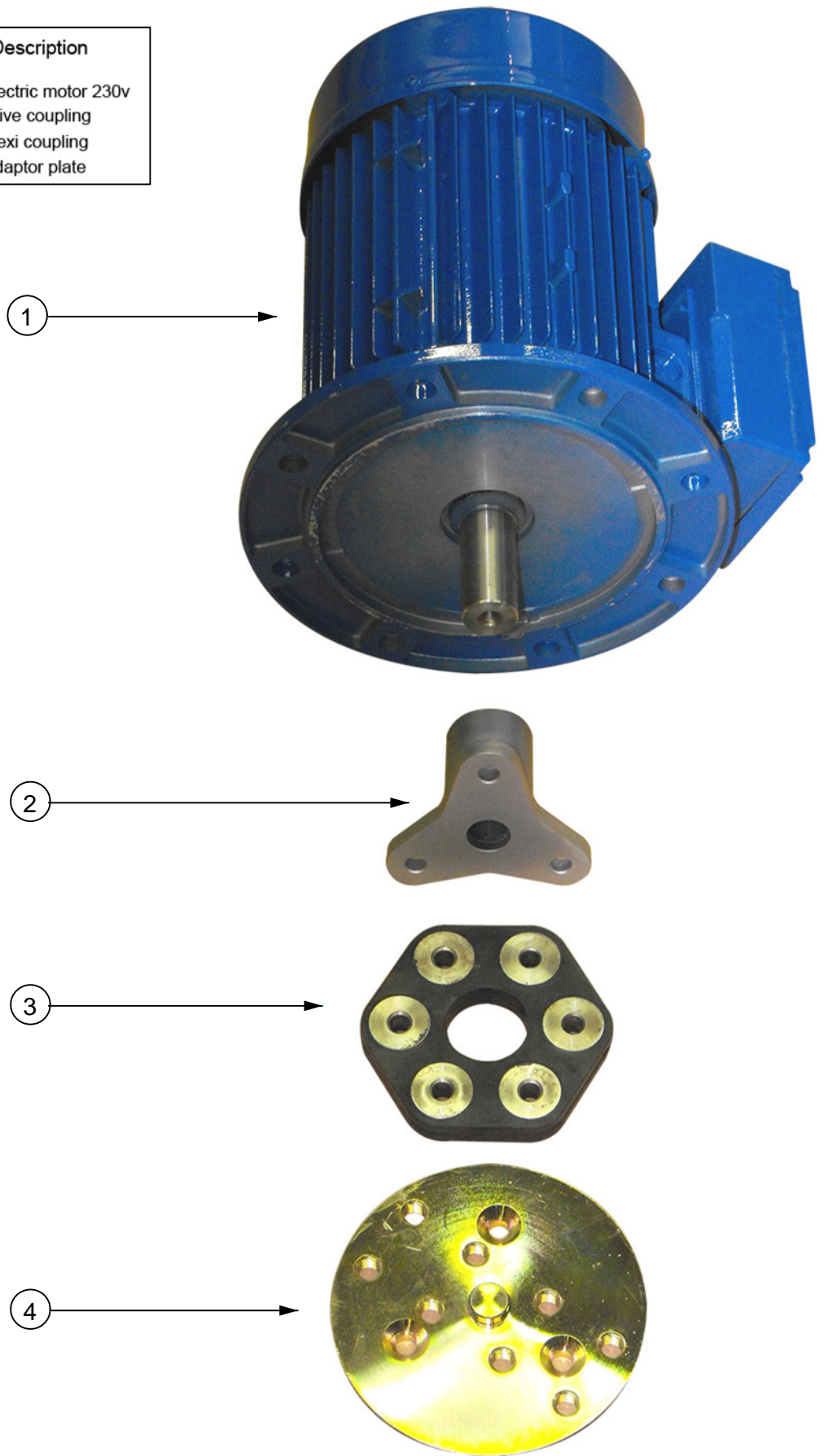

TITLE: Drive Components



SPE International Ltd
 Honeyholes Lane, Dunholme
 Lincoln UK LN2 3SU
 Tel: +44 (0)1673 860709
 Fax: +44 (0)1673 860330
 Web: www.spe-int.com
 Email: info@spe-int.com

Machine: DFG200-3

Revision: 1.01

Drawn: PM

Checked: BJ

Date: 07/12/2009

THIS DRAWING AND ASSOCIATED COPYRIGHT IS
 THE PROPERTY OF SPE INTERNATIONAL LTD

Item	QTY	Part Number	Description
1	2	SPCG/LNM20	Gland
2	1	SPLMZ106	Stop button
3	1	SPLMZ111	Enclosure
4	1	SPLMS2516T	Switch
5	1	SP331-3703	Under voltage coil 240v
6	2	SP2520	Reducer

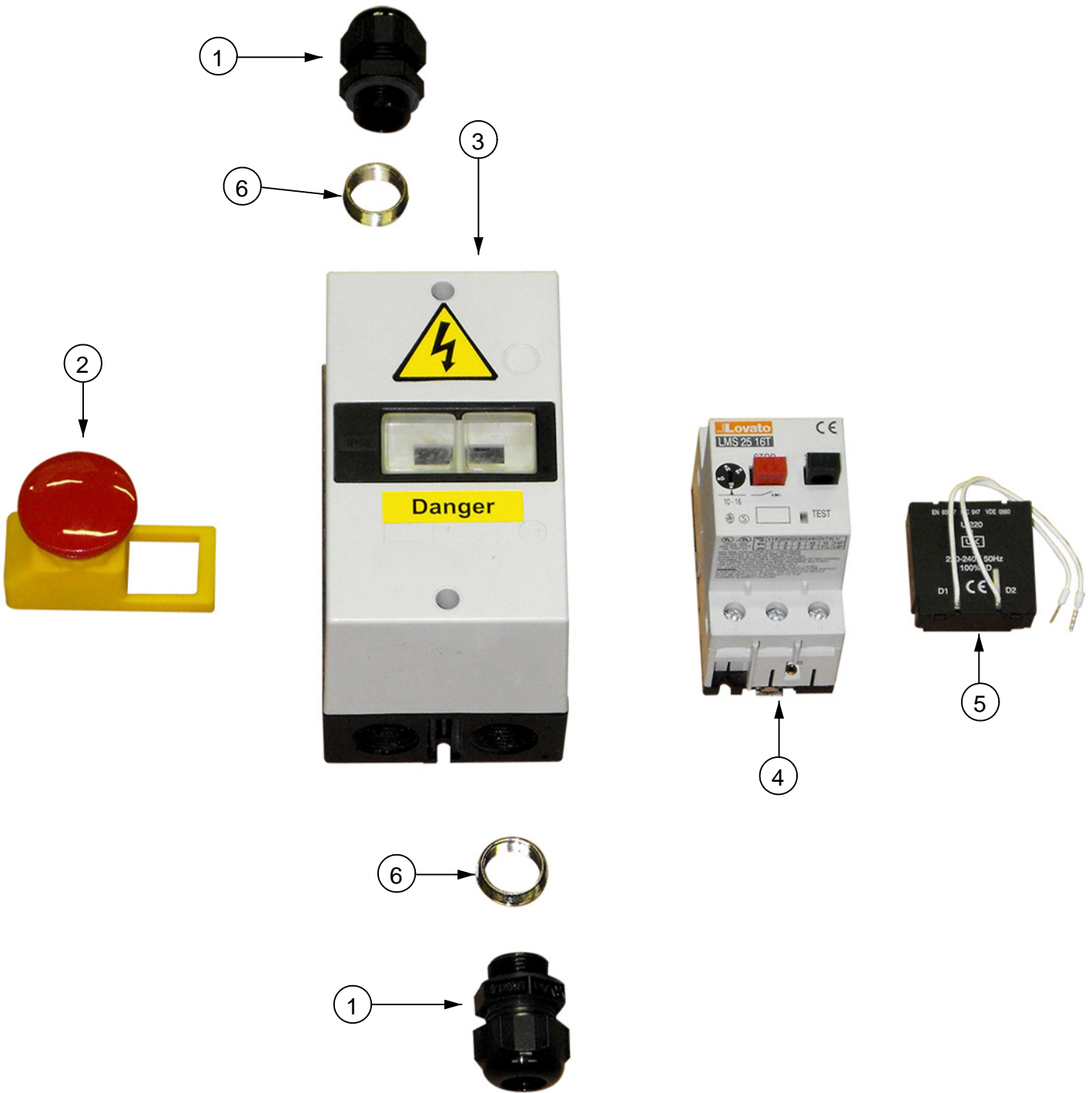

TITLE: Electrical Components



SPE International Ltd
 Honeyholes Lane, Dunholme
 Lincoln UK LN2 3SU
 Tel: +44 (0)1673 860709
 Fax: +44 (0)1673 860330
 Web: www.spe-int.com
 Email: info@spe-int.com

Machine:	DFG200-3	Revision:	1.01
Drawn:	PM	Checked:	BJ
		Date:	06/12/2009

THIS DRAWING AND ASSOCIATED COPYRIGHT IS THE PROPERTY OF SPE INTERNATIONAL LTD

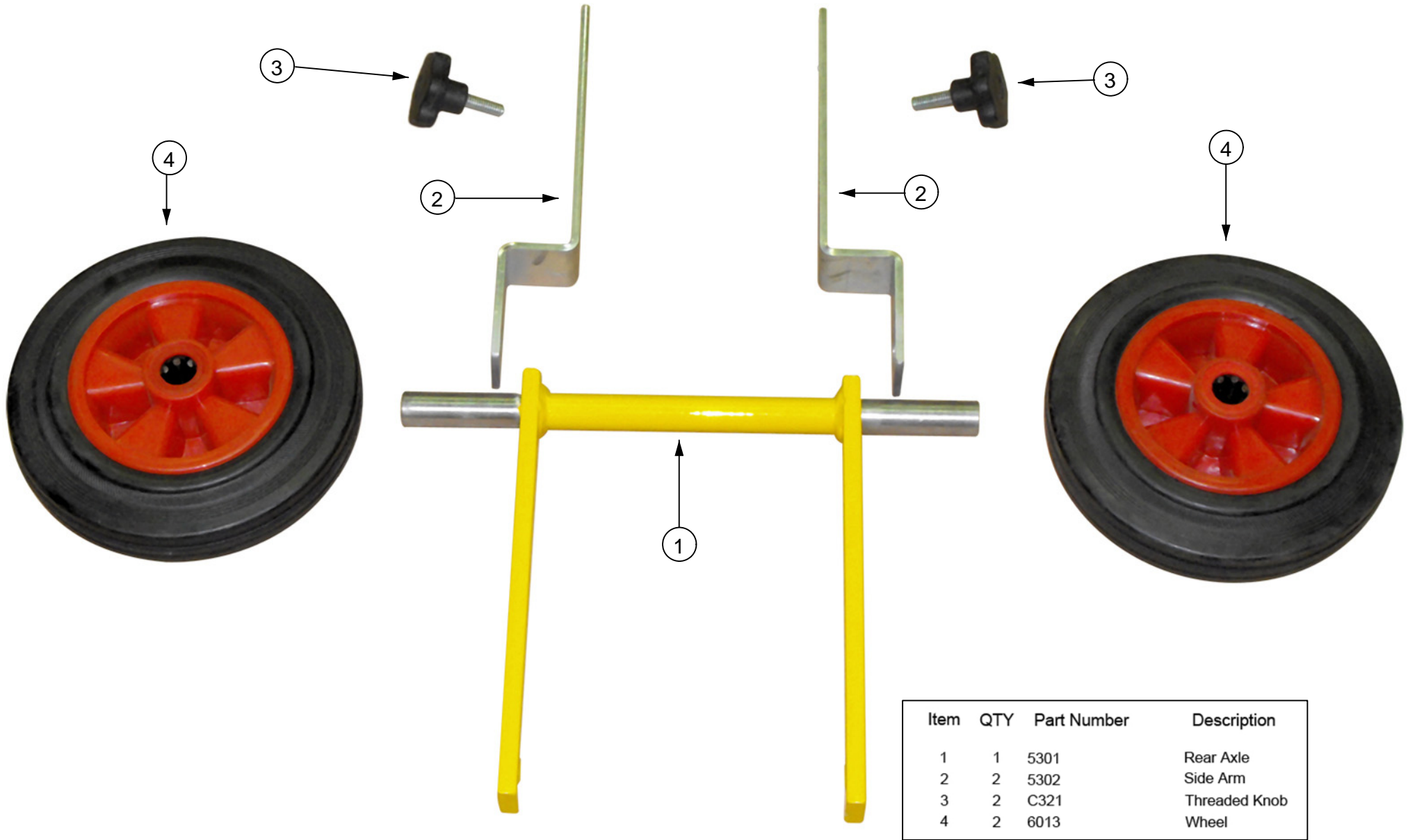

Item	QTY	Part Number	Description
1	1	5301	Rear Axle
2	2	5302	Side Arm
3	2	C321	Threaded Knob
4	2	6013	Wheel

TITLE: Rear Axle Assembly



SPE International Ltd
 Honeyholes Lane, Dunholme
 Lincoln UK LN2 3SU
 Tel: +44 (0)1673 860709
 Fax: +44 (0)1673 860330
 Web: www.spe-int.com
 Email: info@spe-int.com

Machine: DFG200-3
 Drawn: PM
 Checked: BJ
 Revision: 1.00
 Date: 07/12/2009

THIS DRAWING AND ASSOCIATED COPYRIGHT IS THE PROPERTY OF SPE INTERNATIONAL LTD